



**Model FT4A Gas Mass Flow Meter
For Oil & Gas, Industrial, and
Wastewater Applications**

- DDC-Sensor™ technology
- Gas-SelectX®: menu of field selectable gas compositions
- CAL-V® Calibration Validation
- Measures gas flow rate in SCFD, MCFD & many more
- Wide measurement range: up to 1000:1 turndown; 100:1 typical
- 4-20mA for flow rate or temperature; HART communication option
- Choice of second output: pulse output for flow/total or RS485 Modbus RTU
- USB port to connect to a PC, standard
- Free FT4A View™ Software available
- Insertion probes for pipes 1.5" and larger
- Welded, 316 SS sensor construction
- Microprocessor based, field-programmable electronics
- Standard on-board 2 line x 16 character, backlit display with configuration panel
- NIST traceable calibration
- Low-end sensitivity for vents and leak detection
- Negligible pressure drop
- FM (U.S.) & FMc (CANADIAN) approved for Class I, Div 1; ATEX/IECEX approved for Zone 1
- NEMA 4X and CE Mark
- Average Gross Heating Value and Density of Gas Mix
- Accuracy Compliant with BLM 3175 & API 14.10

Model FT4A

Thermal Mass Flow Meter and Temperature Transmitter

Accuracy Compliant with BLM 3175 & API 14.10:

- Flare Gas
- Sales Gas
- Fuel Gas



Expansion of the Gas-SelectX® Menu

Many customers need a fast solution to their monitoring needs. For these cases, FOX has developed the Gas-SelectX® calibration gas menu feature for the Model FT4A flowmeter. Gas-SelectX® allows the user to choose from a menu of several common gases or gas mixtures for their application.

The Gas-SelectX® feature has three gas menus with the following available gases:

Pure Gas Menu	Mixed Gas Menu	O&G Gas Menu
Air	Air	Methane (C1)
Argon	Argon	Ethane (C2)
Butane	Butane	Propane (C3)
Carbon Dioxide	Carbon Dioxide	i-Butane (C4)
Methane	Methane	n-Butane (C4)
Natural Gas	Nitrogen	Pentanes (C5)
Nitrogen	Oxygen	Hexanes (C6)
Oxygen	Helium	Carbon Dioxide
Helium	Hydrogen	Nitrogen
Hydrogen	Propane	Heptanes (C7)
Propane		Octanes (C8)
		Nonane+ (C9+)

The meter's proprietary algorithms allow the user to switch gases or gas mixes in the field, as needed. The Pure and Mixed Gas Menus make the FT4A ideal for measurement of digester gas, Liquefied Petroleum Gas (LPG) and a variety of other biogases. With the addition of the O&G Menu on the Model FT4A, Gas-SelectX® can be used in upstream Oil & Gas applications. Whether you need to measure natural gas, air, flare gas, vent gas, or digester gas, the FT4A brings these options and more to the user with a quick push of a button.

FOX THERMAL INSTRUMENTS, INC.
399 RESERVATION ROAD
MARINA, CA 93933
PHONE: 831-384-4300
FAX: 831-337-5786
sales@foxthermalinstruments.com
www.foxthermalinstruments.com

MODEL FT4A

Fast and Flexible Gas Flow Measurement

Offering you the flexibility to monitor multiple gas types at the push of a button, rotate the housing as needed for tight installations, and configure meter settings from advanced software, the FOX Model FT4A thermal mass flow meter and temperature transmitter can be used in a large variety of Oil & Gas, Industrial, and Wastewater gas flow measurement applications.

Theory of Operation

Fox Thermal Flow Meters use a constant temperature differential (constant ΔT) technology to measure mass flow rate of air and gases. The thermal mass flow sensor consists of two Resistance Temperature Detectors (RTD's).

The Reference RTD measures the gas temperature. The instrument electronics heat the mass flow sensor, or heated element, to a constant temperature differential (constant ΔT) above the gas temperature and measures the cooling effect of the gas flow. The electrical power required to maintain a constant temperature differential is directly proportional to the gas mass flow rate. The microprocessor linearizes this signal to deliver a linear 4-20mA signal.

Fox Model FT4A Thermal Gas Mass Flow Meter Features

The Fox Model FT4A measures gas flow rate in standard units without the need for temperature or pressure compensation. It provides an isolated 4-20mA output (with a HART option) and a selection of pulse or RS485 Modbus RTU.

With a standard on-board 2-line x 16-character, backlit display, operators can view flow rate, total, elapsed time, process gas temperature, and alarms. The display is also used in conjunction with the Configuration Panel to access flow meter settings, such as 4-20mA and pulse output scaling, pipe diameter, zero flow cutoff, flow filtering (damping), display options, and high or low alarm limits.

The Model FT4A has an insertion probe and is easily installed by drilling a hole in the pipe and welding on a 1" NPT coupling. A Fox-supplied compression fitting secures the probe in place. It is supplied with 316 stainless steel wetted materials standard. A USB port to connect to a computer or laptop is standard; interface options include 4-20mA, pulse, HART, and RS485 Modbus RTU.

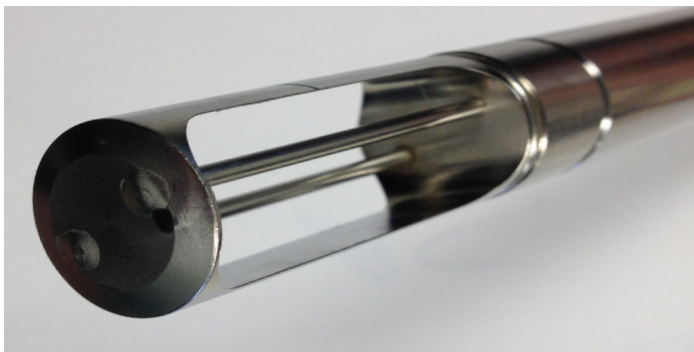

The Fox 2nd generation DDC Sensor™ eliminates the sensor element vibration which can lead to metal fatigue and failure.



The Model FT4A flowmeter and temperature transmitter is approved for FM/FMc Class I, Division 1, ATEX/IECEx Zone 1. CE Mark. Accuracy compliant with BLM 3175 & API 14.10.

Advanced Features

Suitable for harsh and hazardous environments, the instrument features:

- Robust DDC-Sensor™ Design
- Gas-SelectX® gas selection menu featuring new Oil & Gas Menu
- CAL-V® Calibration Validation
- Rotatable probe: allows ± 180 degree swivel
- FM/FMc, ATEX, IECEx approvals. CE mark.
- 10-30VDC power input, standard
- NIST-traceable calibration
- Free FT4A View™ Software
- High and low alarm limits
- 40 Daily Totals (24 hour totals)
- Wetted materials are all welded, 316 stainless steel

Perfect for Oil & Gas, Industrial, and Wastewater applications, the Model FT4A is the latest instrument offered in the FOX product line.

CAL-V®

For customers that need a quick and easy way to verify the calibration of the meter in the field, the Model FT4A offers the CAL-V® feature. This feature can be accessed and run through the meter's standard display and configuration panel, Modbus, or the FT4A View™ Software. The test takes less than 5 minutes to run and produces a pass/fail result at the conclusion of the test. A fail result may indicate either a dirty sensor or the need to recalibrate.

If the CAL-V® test is performed using the FT4A View™ software, a Calibration Validation Certificate can be produced at the conclusion of the test. The certificate will show the date and time of the test along with meter data such as firmware version, meter serial number, configuration settings, and currently selected gas/gas mix. This in situ calibration validation helps operators comply with environmental mandates and eliminates the cost and inconvenience of annual factory calibration.

DDC-Sensor™

The Fox DDC-Sensor™ is the state-of-the-art sensor technology used in the Fox Model FT4A Thermal Gas Flow Meter. The DDC-Sensor™, a Direct Digitally Controlled sensor, is unlike other thermal flow sensors available on the market. Instead of using traditional analog circuitry, the DDC-Sensor™ is interfaced directly to the FT4A microprocessor for more speed and programmability. The DDC-Sensor™ accurately responds to changes in process variables (gas flow rate, pressure, and temperature) to determine mass flow rate, totalized flow, and temperature.

Fox's DDC-Sensor™ provides a technology platform for calculating accurate gas correlations. The FT4A correlation algorithms allow the meter to be calibrated on a single gas in the factory while providing the user the ability to select other gases or gas mixes in the Gas-SelectX® menu. Fox's Model FT4A with its DDC-Sensor™ and advanced correlation algorithm provides an accurate, multi-gas-capable thermal gas flow meter.

FT4A View™ Software

FOX has developed advanced software - FT4A View™ - a free PC-compatible application available for download from the FOX website. Connect your laptop, PC, or control station to the meter using the USB port interface to access the meter's data and configure the meter's settings.

FT4A View allows:

- Quick access to all configuration parameters and available gas selections
- Selection of measurement units, flow and temperature ranges, alarm settings and more
- Display of alarm codes
- Storage of meter configurations to a file that can be archived
- Raw data to be viewed in order to diagnose or troubleshoot your meter
- Data logging to an Excel™ spreadsheet
- View gas mix average gross heating value and density

DIMENSIONS

Meter Dimensional Drawings

Drawings of the Model FT4A meter and retractor dimensions are shown here in inches (mm).

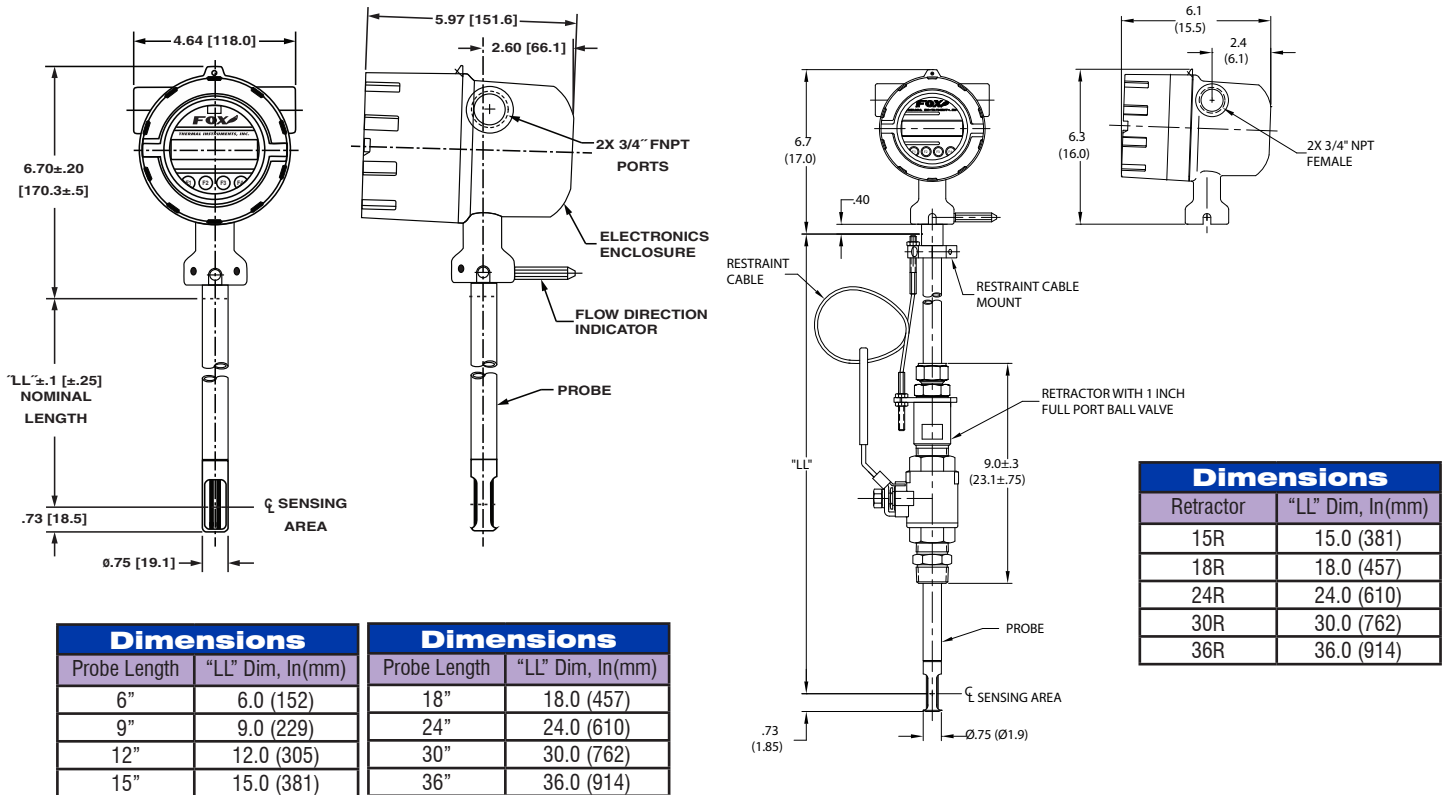

SPECIFICATIONS

Performance Specs

Flow Accuracy:

- Air: $\pm 1\%$ of reading $\pm 0.2\%$ of full scale
- Other gases: $\pm 1.5\%$ of reading $\pm 0.5\%$ of full scale
- Accuracy specification applies to customer's selected flow range
- Maximum range: 15 to 60,000 SFPM (0.07 to 280 NMPS)
- Minimum range: 15 to 1,000 SFPM (0.07 to 4.7 NMPS)
- Straight, unobstructed pipe requirement:
15 diameters upstream; 10 downstream.

Flow Repeatability: $\pm 0.2\%$ of full scale

Flow Response Time: 0.8 seconds (one time constant)

Temperature Accuracy: $\pm 1^\circ\text{F}$ ($\pm 0.6^\circ\text{C}$)

Calibration:

- Factory Calibration to NIST traceable standards
- CAL-V®: In-situ, operator-initiated calibration validation

Operating Specs

Gas-SelectX® Gas Selections:

Pure Gas, Mixed Gas, and Oil & Gas Mixed Gas Menus to suit any application. See the Fox website for more information on availability of current gases.

Units of Measurement:

SCFM, SCFH, NM3/M, NM3/H, NM3/D, NLPS, NLPM, NLPH, MCFD, MSCFD, SCFD, MMSCFD, MMSCFM, SM3/D, SM3/H, SM3/M, LB/S, LB/M, LB/H, LB/D, KG/S, KG/M, KG/H, SLPM, MT/H

Flow Velocity Range: 15 to 60,000 SFPM (0.07 to 280 NMPS)

Turndown: up to 1000:1; 100:1 typical

Flow Ranges			
Pipe Diameter	SCFM	MSCFD	NM3/Hr
1.5" (40mm)	0 - 850	0 - 1,220	0 - 1,520
2" (50mm)	0 - 1,400	0 - 2,020	0 - 2,504
3" (80mm)	0 - 3,080	0 - 4,440	0 - 5,508
4" (100mm)	0 - 5,310	0 - 7,650	0 - 9,496
6" (150mm)	0 - 12,040	0 - 17,340	0 - 21,530
8" (200mm)	0 - 20,850	0 - 30,020	0 - 37,284
12" (300mm)	0 - 46,650	0 - 67,180	0 - 83,420

Note: To determine if the FT4A will operate accurately in other pipe sizes, divide the maximum flow rate by the pipe area. The application is acceptable if the resulting velocity is within the velocity range above. Check Fox website for velocity calculator.

Gas Pressure insertion meter: 500 psig (34.5 barg) max.

Gas Pressure retractor: 150 psig (10.3 barg) max.

Relative Humidity: 90% RH maximum; non-condensing

Temperature:

DDC-Sensor™: -40 to 250°F (-40 to 121°C)

Enclosure: -40 to 158°F (-40 to 70°C)*

*Note: Display dims below -4°F (-20°C); function returns once temperature rises again.

Input power: 12 to 28 VDC, 6 watts max. (CE requirement)

Full input power range: 10 to 30 VDC.

Outputs:

- One standard isolated 4-20mA output for flow or temperature; fault indication per NAMUR NE43; HART communication option.
- Second output for pulse or RS485 Modbus RTU.
- Isolated pulse output: 5 to 24VDC, 10mA max., 0 to 100Hz for flow (the pulse output can be used as an isolated solid state output for alarms).

Serial Communication:

USB connector for connecting to a laptop or computer is standard.

Optional isolated communication outputs: RS485 Modbus RTU. Free PC-based software tool - FT4A View™ - provides complete configuration, remote process monitoring and data logging functions.

4-20mA and Pulse Verification:

Simulation mode used to align 4-20mA output and pulse output (if ordered) with the input to customer's PLC/DCS.

Physical Specs

Sensor Material: 316 stainless steel

Enclosure: NEMA 4, aluminum, dual ¾" FNPT conduit entries.

Fox recommends the following probe lengths (without insulation):

Pipe Diameter	Probe Length
1.5" (40mm) to 6" (150mm)	6-inch
8" (200mm) to 12" (300mm)	9-inch
14" (350mm) to 18" (450mm)	12-inch

Use the equation below for larger pipe sizes

Probe Lengths (LL*) in inches(cm) =

6.0 (15.2) 9.0 (22.9) 12.0 (30.5)

15.0 (38.1) 18.0 (45.7) 24.0 (61.0)

30.0 (76.2) 36.0 (91.4)

*See dimensional drawing on page 3.

Dimensional

Probe diameter: ¾"

Equation for selecting flow meter probe length:

Probe length = ½ pipe ID (in inches) + 3" + 10" (for retractor, if any) + thickness of insulation (if any). Round up to the next standard probe length available.

Approvals

CE Mark: Approved

EMC Directive: 2014/30/EU

Emissions and Immunity Testing: EN61326-1:2013

FM (U.S.) & FmC (CANADA): Approved

Class I, Division 1, Groups B, C, D; Class II, Division 1, Groups E, F, G; and Class III, Division 1; T4, Ta = -40° to 70°C; Class I, Zone 1, AEx/Ex db IIB + H2 T4; Gb Ta = -40°C to 70°C; Type 4X, IP66/67

ATEX (FM16ATEX0013X): Approved

II 2 G Ex db IIB + H2 T4; Gb Ta = -40°C to 70°C; IP66/67

II 2 D Ex tb IIIC T135°C; Db Ta = -40°C to 70°C; IP66/67

IECEx (IECEx FMG 16.0010X): Approved

Ex d IIB + H2 T4; Gb Ta = -40°C to 70°C; IP66/67

Ex tb IIIC T135°C; Db Ta = -40°C to 70°C; IP66/67

ATEX and IECEx Standards:

EN 60079-0:2012 + A11:2013 IEC 60079-0:2011

EN 60079-1:2014 IEC 60079-1:2014

EN 60079-31:2014 IEC 60079-31:2013

EN 60529:1991 + A1:2000 IEC 60529:2001